

POULIE POUR COURROIE POLYCHAIN® GT-14M

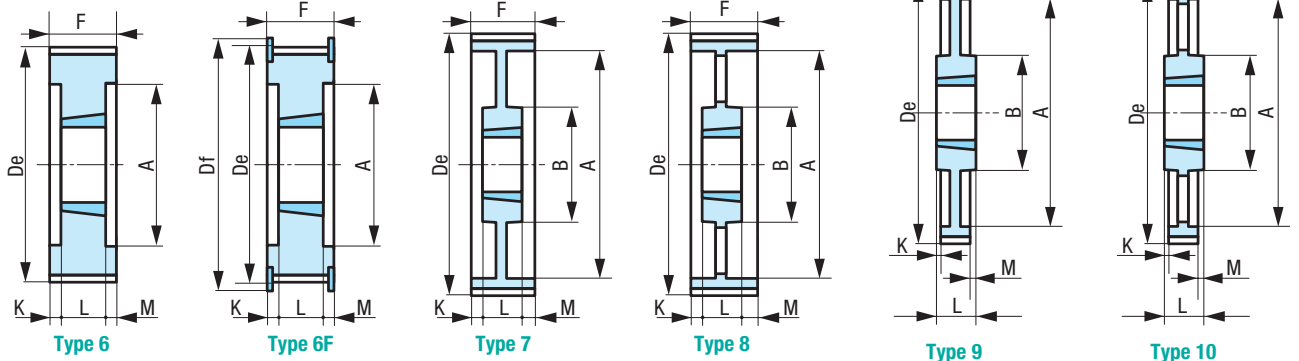
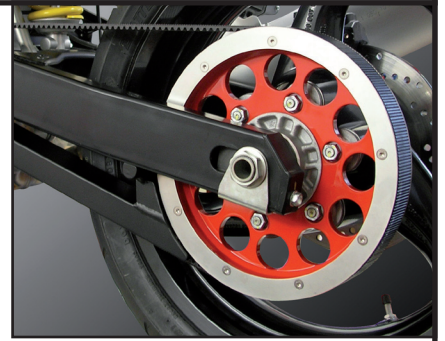
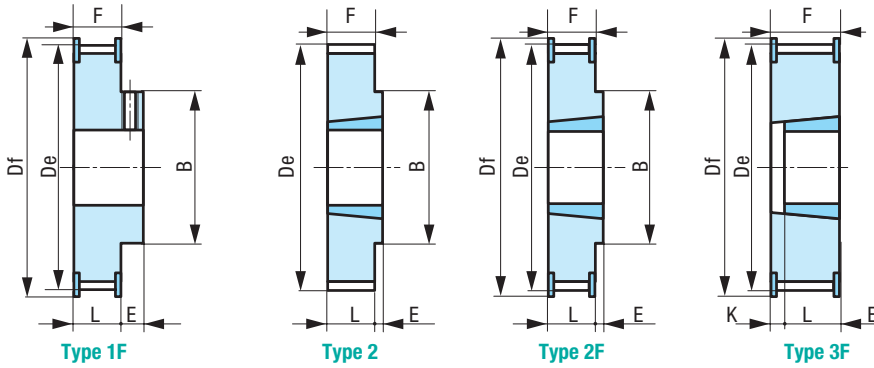

POLY.P				POLY-P x (Nb de dents) x 14 M - 20										POLY-P x (Nb de dents) x 14M - 37									
				Largeur courroie : 20mm ▶ F = 33										Largeur courroie : 21mm ▶ F = 30									
Nb de dents	Dp	DE	Df	Forme	A	B	E	K	L	M	Matière	N° moyeu	Forme	A	B	E	K	L	M	Matière	N° moyeu		
28	124,78	121,98	141	3F	-	-	-	1	32	-	F	2012	5F	88	-	-	-	32	19	F	2012		
30	133,69	130,89	141	3F	-	-	-	1	32	-	F	2012	5F	98	-	-	3	45	3	F	2517		
32	142,6	139,8	155	3F	-	-	-	1	32	-	F	2012	6F	100	-	-	3	45	3	F	2517		
34	151,52	148,72	169	2F	-	117	12	-	45	-	F	2517	6F	109	-	-	3	45	3	F	2517		
36	160,43	157,63	169	2F	-	117	12	-	45	-	F	2517	5F	117	-	-	-	45	6	F	2517		
38	169,34	166,54	183	2F	-	117	12	-	45	-	F	2517	5F	126	-	-	-	45	6	F	2517		
40	178,25	175,45	197	2F	-	117	12	-	45	-	F	2517	5F	135	-	-	-	45	6	F	2517		
44	196,08	193,28	211	2F	-	144	18	-	51	-	F	3020	3F	-	-	-	0	51	-	F	3020		
48	213,9	211,11	226	2F	-	144	18	-	51	-	F	3020	3F	-	-	-	0	51	-	F	3020		
50	222,82	220,02	239	2F	-	144	18	-	51	-	F	3020	3F	-	-	-	0	51	-	F	3020		
56	249,55	246,76	267	9F	207	144	-	9	51	9	F	3020	7F	207	144	-	0	51	0	F	3020		
60	267,38	264,58	-	9	224	159	-	9	51	9	F	3020	7	224	159	-	0	51	0	F	3020		
64	285,21	282,41	-	9	242	159	-	9	51	9	F	3020	7	242	159	-	0	51	0	F	3020		
72	320,86	318,06	-	9	278	159	-	9	51	9	F	3020	7	278	159	-	0	51	0	F	3020		
80	356,51	353,71	-	9	314	159	-	9	51	9	F	3020	7	314	159	-	0	51	0	F	3020		
90	401,07	398,27	-	10	360	159	-	9	51	9	F	3020	8	360	159	-	0	51	0	F	3020		
112	499,11	496,31	-	10	456	159	-	9	51	9	F	3020	8	456	159	-	0	51	0	F	3020		
140	623,89	621,09	-	10	581	159	-	9	51	9	F	3020	10	581	206	-	7	65	7	F	3525		
168	748,66	745,87	-										10	706	206	-	7	65	7	F	3525		
192	855,61	852,82	-										10	812	215	-	12,5	76	12,5	F	4030		
POLY.P				POLY-P x (NB DE DENTS) x 14 M - 68										POLY-P x (NB DE DENTS) x 14M - 90									
				largeur courroie : 68mm ▶ F = 84										largeur courroie : 90mm ▶ F = 106									
Nb de dents	Dp	DE	Df	Forme	A	B	E	K	L	M	Matière	N° moyeu	Forme	A	B	E	K	L	M	Matière	N° moyeu		
34	151,52	148,72	162	1F	-	134	20	-	104	-	A	plein	1F	-	141	30	-	136	-	A	plein		
36	160,43	157,63	168	1F	-	141	20	-	104	-	A	plein	1F	-	147	30	-	136	-	A	plein		
38	169,34	166,54	183	1F	-	147	20	-	104	-	A	plein	1F	-	156	30	-	136	-	A	plein		
40	178,25	175,45	197	1F	-	156	20	-	104	-	A	plein	1F	-	185	30	-	136	-	A	plein		
44	196,08	193,28	211	6F	153	-	-	16,5	51	16,5	F	3020	1F	-	171	-	-	20	66	20	A	3525	
48	213,9	211,11	226	5F	171	-	-	-	51	33	F	3020	6F	180	-	-	20	66	20	F	3525		
50	222,82	220,02	239	6F	180	-	-	9,5	65	9,5	F	3525	6F	180	-	-	20	66	20	F	3525		
56	249,55	246,76	267	6F	207	-	-	9,5	65	9,5	F	3525	6F	207	-	-	20	66	20	F	3525		
60	267,38	264,58	-	6	224	-	-	9,5	65	9,5	F	3525	6	224	-	-	20	66	20	F	3525		
64	285,21	282,41	-	6	242	-	-	9,5	65	9,5	F	3525	6	242	-	-	20	66	20	F	3525		
72	320,86	318,06	-	7	278	178	-	9,5	65	9,5	F	3525	7	278	178	-	20	66	20	F	3525		
80	356,51	353,71	-	7	314	178	-	9,5	65	9,5	F	3525	7	314	215	-	15	76	15	F	4030		
90	401,07	398,27	-	8	360	178	-	9,5	65	9,5	F	3525	7	360	215	-	15	76	15	F	4030		
112	499,11	496,31	-	8	456	178	-	9,5	65	9,5	F	3525	8	456	215	-	8	90	8	F	4535		
140	623,89	621,09	-	8	581	206	-	9,5	65	9,5	F	3525	8	581	215	-	8	90	8	F	4535		
168	748,66	745,87	-	8	706	206	-	9,5	65	9,5	F	3525	8	706	267	-	2	102	2	F	5040		
192	855,61	852,82	-	8	812	215	-	4	76	4	F	4030	8	812	267	-	2	102	2	F	5040		

Poulies également disponibles pour courroies de largeur 125 : références Poly-P-38-14M 125 à Poly-P-192-14m125 : Caractéristiques et formes sur demande.

PRUD'HOMME TRANSMISSIONS - F 93203 SAINT-DENIS CEDEX - TEL. 01 48 11 46 00 - FAX. 01 48 34 49 49 - www.prudhomme-trans.com - info@prudhomme-trans.com
 SOUS RÉSERVE DE TOUTE MODIFICATION DE CONSTRUCTION OU D'ERREUR TYPOGRAPHIQUE DONNÉES TECHNIQUES ET PRIX MODIFIABLES SANS PREAVIS