

KONICLAMP® SÉRIE LOURDE

TYPE 939 EN ACIER - TYPE 999 EN ALUMINIUM

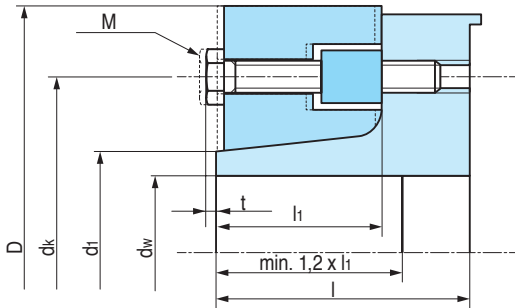

Désignation KON Type Taille dw X

(X = taille du MODULFLEX avec X = O si application différente)

Ex. : KON 93940356,4

(Koniclump en acier de taille 40, d'alésage 35 pour un Modulflex de taille 6,4)

Taille	dw mm	Couple Tmax. (Nm)		Vitesse n (tr/mm)		Dimensions					M Din933	Ma (Nm)		Taille Modulflex	l mm	Taille Modulflex	l mm	
		939	999	999	939	D	d1	l1	tmax	dk		939	999					
30	20	350	350	28000	13000	88	34	33	5	60	M8 x M6	10,9	8,1	920-6,4 980-6,4	52	-	-	
	25	850	850															
	30	1200	1200															
40	30	1700	1700	19000	10300	110	45	45	6	70	M8 x M8	26,2	19,4	920-11 980-11	64	920-11 980-11	64	
	35	2200	2200															
	40	3150	3150															
50	40	3150	3150	18000	9800	139	56	46	7	90	M8 x M10	52	38,7	920-17 980-17	65	920-17 980-17	65	
	45	4000	4000															
	50	5000	5000															
60	50	5000	5000	17000	8000	146	67	51	7	100	M8 x M10	52	38,7	920-28 980-28	69	920-28 980-28	72	
	55	6500	6500															
	60	8000	8000															
75	60	8000	8000	10000	7100	164 168	84	56	8	120	M8 x M12	90	66,4	920-45 980-45	79	920-45 980-45	77	
	65	9800	9800															
	70	11600	11600															
90	75	12500	12500	8000	6400	178 184	98	60	10	140	M8 x M12	90	66,4	920-64 980-64	85	920-64 980-64	92	
	75	12500	12500															
	80	14800	14800															
105	85	17400	17400	7200	5700	222 226	115	67	10	170	M8 x M16	216	160,5	920-110 980-110	100	920-110 980-110	98,5	
	90	20000	20000															
	95	24300	24300															
120	100	27800	27800	5600	5000	248 256	133	79	11	190	M8 x M16	216	160,5	920-170 980-170	112	920-170 980-170	117	
	105	31500	31500															
	110	41500	41500															
135	115	46000	46000	4800	4400	285 294	150	100	14	210	M8 x M20	424	324,3	920-280 980-280	144	920-280 980-280	138	
	120	50000	50000															
	120	62000	62000															
155	125	69000	69000	4300	3900	325	173	121	15	245	M8 x M24	730	556,2	920-450 980-450	166	920-450 980-450	174	
	130	74500	74500															
	135	80000	80000															
175	135	90000	90000	3900	3500	366	196	159	21	280	M8 x M30	1455	1115	920-640 980-640	215	920-640 980-640	212	
	145	107000	107000															
	155	125000	125000															
195	155	145000	145000	3400	3000	412	223	186	21	315	M8 x M30	1455	1115	920-1100 980-1100	242	920-1100 980-1100	249	
	165	168000	168000															
	175	193000	193000															
225	175	193000	193000	-	-	2800	465	251	203	26	360	M8 x M36	2524	-	920-1700	270	920-1100	266
	185	265000	265000															
	195	300000	285000															
255	195	300000	340000	-	-	2200	508	290	278	21	386	M16 x M30	1455	-	900-100000 à 900-120000	345	-	-
	205	340000	382000															
	215	382000	425000															
295	225	425000	495000	-	-	2000	550	325	315	28	450	M12 x M36	2524	-	900-100000 à 900-120000	345	-	-
	235	495000	545000															
	245	545000	600000															
335	255	600000	660000	-	-	1400	740	420	391	26	600	M20 x M36	2524	-	900-100000 à 900-120000	345	-	-
	265	660000	720000															
	275	720000	780000															
385	285	780000	840000	-	-	1400	740	420	391	26	600	M20 x M36	2524	-	900-100000 à 900-120000	345	-	-
	295	840000	915000															
	305	915000	1060000															
385	315	980000	1130000	-	-	1400	740	420	391	26	600	M20 x M36	2524	-	900-100000 à 900-120000	345	-	-
	325	1060000	1130000															
	335	1130000	1300000															
385	335	1130000	1300000	-	-	1400	740	420	391	26	600	M20 x M36	2524	-	900-100000 à 900-120000	345	-	-
	345	1300000	1500000															
	355	1500000	1700000															
385	365	1700000	1900000	-	-	1400	740	420	391	26	600	M20 x M36	2524	-	900-100000 à 900-120000	345	-	-
	375	1900000	2000000															
	385	2000000	2000000															

Tolérance d'alésage et d'arbre dw
< 160 : H7/h6
> 160 : H7/g6

Rugosité de l'arbre
Rz < 16 µ

En cas d'usinage d'un alésage non standard
se situant entre 2 valeurs du tableau ou inférieur au plus petit alésage de la taille, faire la moyenne arithmétique pour avoir le couple transmis

Vitesses supérieures à celles indiquées sur les tableaux : réalisables sur demande

