

GALETS DE CAMES

SÉRIE NATR - NATV

Désignation NATR/TV/TR..PP/NATV..PP d

Ex.: NATV10

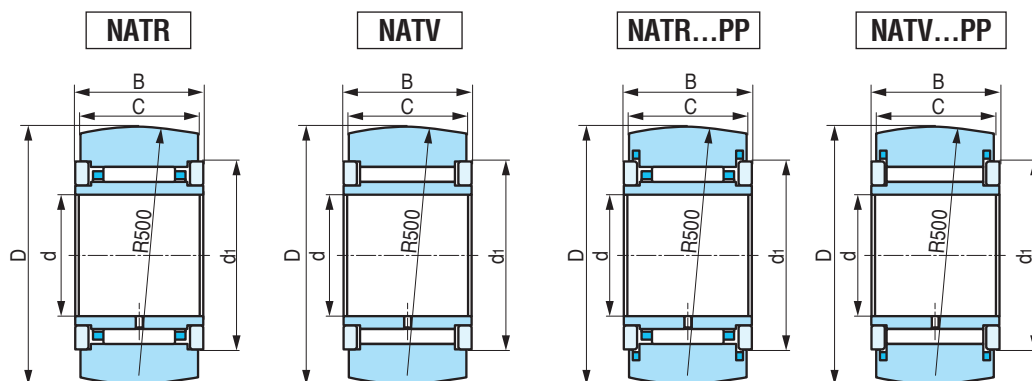

Réf. sans joint hermetique	Réf. avec joint hermetique	Poids g	Dimensions (mm)					ø Axe mm	Charge		Vitesse limite lubrification par graisse Tr/mn.
			d	D	B	C	d1		Dynamique	Statique	
NATR5	NATR5 PP	14	5	16	12	11	12	16	3050	3000	22000
NATV5	NATV5 PP	15	5	16	12	11	12	16	4500	6300	8500
NATR6	NATR6 PP	20	6	19	12	11	14	19	3600	36500	20000
NATV6	NATV6 PP	21	6	19	12	11	14	19	5700	8700	7000
NATR8	NATR8 PP	41	8	24	15	14	19	24	4500	5400	5000
NATV8	NATV8 PP	42	8	24	15	14	19	24	8600	12000	5500
NATR10	NATR10 PP	64	10	30	15	14	23	30	6100	7800	11000
NATV10	NATV10 PP	65	10	30	15	14	23	30	10900	17000	4500
NATR12	NATR12 PP	71	12	32	15	14	25	32	6600	9800	9000
NATV12	NATV12 PP	72	12	32	15	14	25	32	11800	19000	3900
NATR15	NATR15 PP	103	15	35	19	18	27	35	10500	17500	7000
NATV15	NATV15 PP	105	15	35	19	18	27	35	16000	32500	3400
NATR17	NATR17 PP	144	17	40	21	20	32	40	11800	19400	6000
NATV17	NATV17 PP	152	17	40	21	20	32	40	19600	37000	29000
NATR20	NATR20 PP	246	20	47	25	24	37	47	17500	29800	4900
NATV20	NATV20 PP	254	20	47	25	24	37	47	25800	57000	2600
NATR25	NATR25 PP	275	25	52	25	24	42	52	19500	36500	3600
NATV25	NATV25 PP	285	25	52	25	24	42	52	29000	69600	200
NATR30	NATR30 PP	470	30	62	29	28	51	62	31000	57500	2600
NATV30	NATV30 PP	481	30	62	29	28	51	62	45500	104000	1700
NATR35	NATR35 PP	635	35	72	29	28	58	72	34500	67500	2000
NATV35	NATR35 PP	647	35	72	29	28	58	72	50800	109500	1400
NATR40	NATR40 PP	805	40	80	32	30	66	80	47000	91500	1700
NATV40	NATV40 PP	890	40	80	32	30	66	80	64000	139000	1300
NATR45	NATR45 PP	910	45	82	32	30	72	80	49100	98000	1500
NATR50	NATR50 PP	960	50	90	32	30	76	85	50500	10600	1300
NATV50	NATV50 PP	990	50	90	32	30	76	90	69500	187000	1000

ROUES LIBRES

SÉRIE HF - HFL

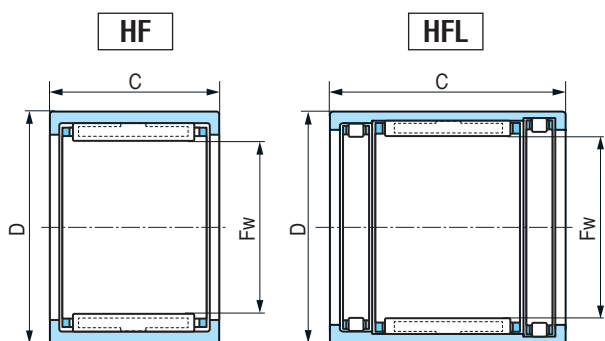

Désignation HF/HFL FW C

Ex.: HF1816

Réf.	Poids g	Dimensions (mm)			ø Axe mm	Vitesse limite (tr/mn.) lubrification par		Couple moteur Nm
		D	C	FW		Graisse	Huile	
HF0406	1	8	6	4	4	34000	14000	0,34
HF0612	3	10	12	6	6	23000	13000	1,76
HF0812	3,5	12	12	8	8	17000	12000	3,15
HF1012	4	14	12	10	10	14000	11000	5,3
HF1216	10,5	18	16	12	12	11000	8000	12,2
HF1416	13	20	16	14	14	9500	8000	17,3
HF1616	14	22	16	16	16	8500	7500	20,5
HF1816	15,5	24	16	18	18	7500	7500	24,1
HF2016	17	26	16	20	20	7000	6500	28,5
HF2520	30,9	32	20	25	25	5500	5500	66
HF3020	36	37	20	30	30	4500	4500	90
HF3520	40	42	20	35	35	3900	3900	121
HFL0822	6,3	12	22	8	8	17000	12000	3,15
HFL1226	18	18	26	12	12	11000	8000	12,2
HFL1426	20,3	20	26	14	14	9500	8000	17,3
HFL1626	22	22	26	16	16	8500	7500	20,5
HFL1826	24,4	24	26	18	18	7500	7500	24,1
HFL2026	27	26	26	20	20	7000	6500	28,5
HFL2530	44	32	30	25	25	5500	5500	66
HFL3030	51	37	30	30	30	4500	4500	90
HFL3530	58	42	30	35	35	3900	3900	121