

ROUES LIBRES HAUTES PERFORMANCES

RLHP

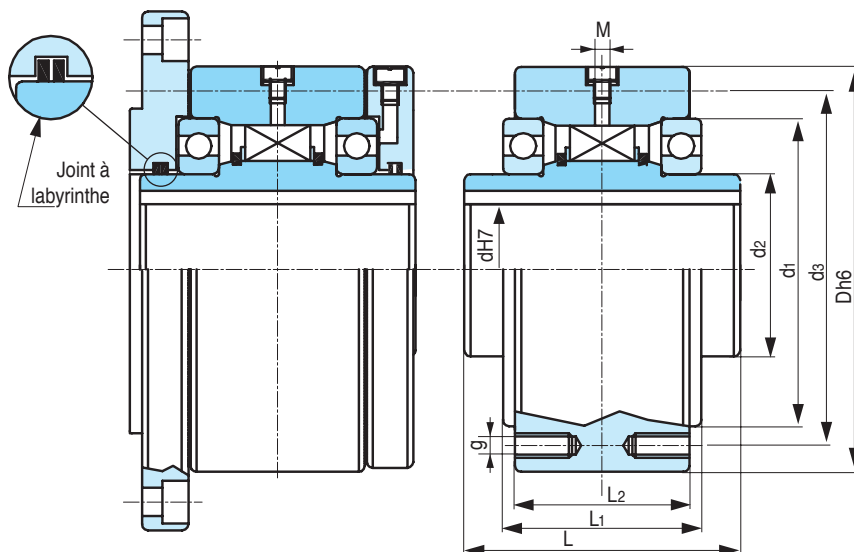

Désignation RLHP d

RLHP	dH7	Dh6	L	L1	L2	d1	d2	d3	z	g	M	nMAX (tr/mn)	nMAX (tr/mn)	TN	Masse
	mm											Bague interne	Bague externe		Kg
25	25	90	60	40	35	68	40	78	4	M6	M4	8200	5600	210	1,5
30	30	100	68	48	43	75	45	87	6	M6	M4	7600	5400	570	2,2
40	40	125	86	59	53	90	55	108	6	M8	M4	6500	4500	1500	4,6
50	50	150	94	72	64	110	70	132	8	M8	M4	5100	3600	2400	7,2
55	55	160	104	72	66	115	75	138	8	M10	M4	4500	3200	2400	8,6
60	60	170	114	89	78	125	80	150	10	M10	M4	3900	2700	1900	10,5
2G 60	60	170	114	89	78	125	80	150	10	M10	M4	3900	2700	3230	10,6
70	70	170	114	89	78	125	100	150	10	M10	M4	3900	2700	1900	11,5
2G 70	70	170	114	89	78	125	100	150	10	M10	M4	3900	2700	3230	11,6
80	80	170	114	89	78	125	100	150	10	M10	M4	3900	2700	1900	10,9
2G 80	80	170	114	89	78	125	100	150	10	M10	M4	3900	2700	3230	11

ANTIDÉVIREUR ADV

Désignation ADV d

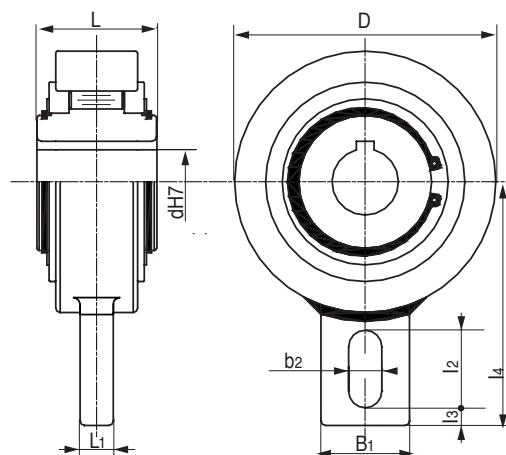

en Stock

Les dimensions tramées



CAGES BLRCA



BAGUES :
NOUS CONSULTER

PRUD'HOMME
transmissions

25 chemin d'Aubervilliers
F-93203 SAINT-DENIS Cedex

Tél. 01 48 11 46 00 - Fax 01 48 34 49 49

www.prudhomme-trans.com

info@prudhomme-trans.com

ADV	dH7	D	L	B1	L1	b2	I2	I3	I4	Masse	nMAX (tr/mn)	TN	Couple résiduel
	mm										Kg	Bague interne	Nm
20	20	83	35	40	12	15	35	5	90	1,3	450	275	0,2
25	25	83	35	40	12	15	35	5	90	1,3	450	275	0,2
30	30	118	54	40	15	15	35	8	110	3,5	320	1250	1,2
35	35	118	54	40	15	15	35	8	110	3,4	320	1250	1,2
40	40	118	54	40	15	15	35	8	110	3,3	320	1250	1,2
45	45	155	54	80	15	18	35	10	140	5,8	300	2180	2,2
50	50	155	54	80	15	18	35	10	140	5,7	300	2180	2,2
55	55	155	54	80	15	18	35	10	140	5,6	300	2180	2,2
60	60	155	54	80	15	18	35	10	140	5,5	300	2180	2,2
70	70	155	54	80	15	18	35	10	140	5,3	300	2180	2,2
80	80	190	64	80	20	20	40	20	155	8,7	200	2930	3,5
90*	90	260	90	120	25	30	50	20	220	24,5	150	7250	3,5
100*	100	260	90	120	25	30	50	20	220	23,5	150	7250	3,5
110*	110	260	90	120	25	30	50	20	220	22,5	150	7250	3,5
120*	120	300	110	120	30	30	50	20	240	42	130	11100	6

* 2 rainures de clavette à 120°